



Project Name \_\_\_\_\_

Item No. \_\_\_\_\_

Quantity \_\_\_\_\_

# Plancha Modular Range Top

## SPECIFICATION

- Heavy Duty modular Plancha rangetop with polished  $\frac{3}{4}$ " thick steel plate. Individual controls enable choice of common plate temperature or graduated heat. Each burner to have a standing pilot and a push-button piezo igniter.
- Unit to have stainless steel front, sides and bottom, welded steel frame and 1- $\frac{1}{4}$ " front manifold with 1" rear gas connection.
- Available in sizes of 18", 24", 30" and 36" wide.
- This unit is modular and mounts on a standard oven, convection oven, cabinet base, refrigerated base or 4" legs for counter models. One of these bases must be ordered to complete this unit. See separate spec sheets for bases.

## STANDARD FEATURES

- Dual (front and back) burner design @ 20,000 Btu/hr per burner – patent pending
- $\frac{3}{4}$ " thick steel cooking plate
- 3- sided stainless steel grease trough
- Front pull-out stainless steel grease drawer
- 4-burners for 30" and 36" wide models
- Standing Pilots, one per burner
- 1  $\frac{1}{4}$ " Front Gas Manifold
- 1" Rear gas supply connection
- Zamak Die Cast Knobs with set screws
- Stainless Steel front, sides and bottom
- Welded Steel frame
- Welded Body construction
- Stainless Steel Front Plate shelf 3  $\frac{5}{8}$ "
- 9" Low Back Flue Riser

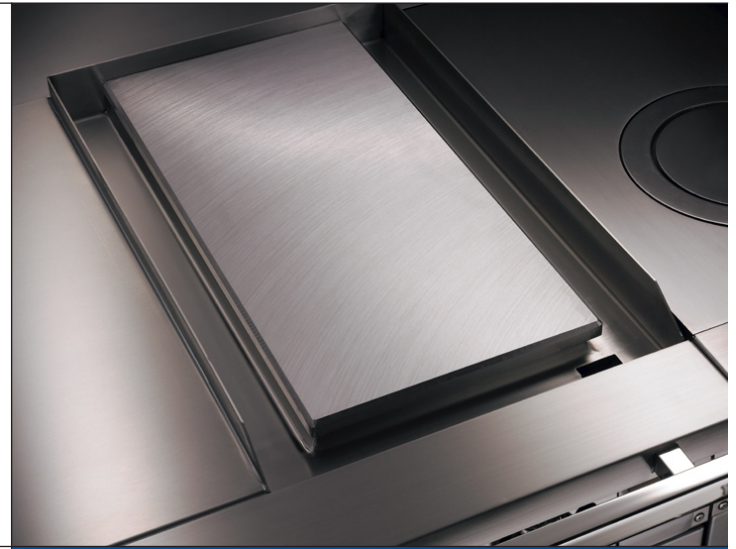

V36P

## OPTIONS

- Stainless Steel Back
- Common Multi-unit Plate Shelf up to 108"
- Extended Plate Shelf 6"
- Extended Plate Shelf 8"
- Belly Bar with 1" space
- Belly Bar with space for 1/9 condiment pans
- Cap and Cover manifold ends
- Flue Risers: 1" Island Trim, 25" high Half Back or 39" high Tall Back
- Shelving: single, 25" or 39" high and double 39" high with either solid shelf, tubular or a combination
- Legs 4" high for counter model
- 1" Pressure regulator (shipped separately)

**Note:** All Viking units are modular. Rangetops are separate units and have separate model numbers from bases. To complete a range there must be a base item added, such as oven, cabinet base, refrigerated base or legs.

**Example:** A 6 burner range with oven would be a V36B6 plus a V36SO



Project Name \_\_\_\_\_

Item No. \_\_\_\_\_

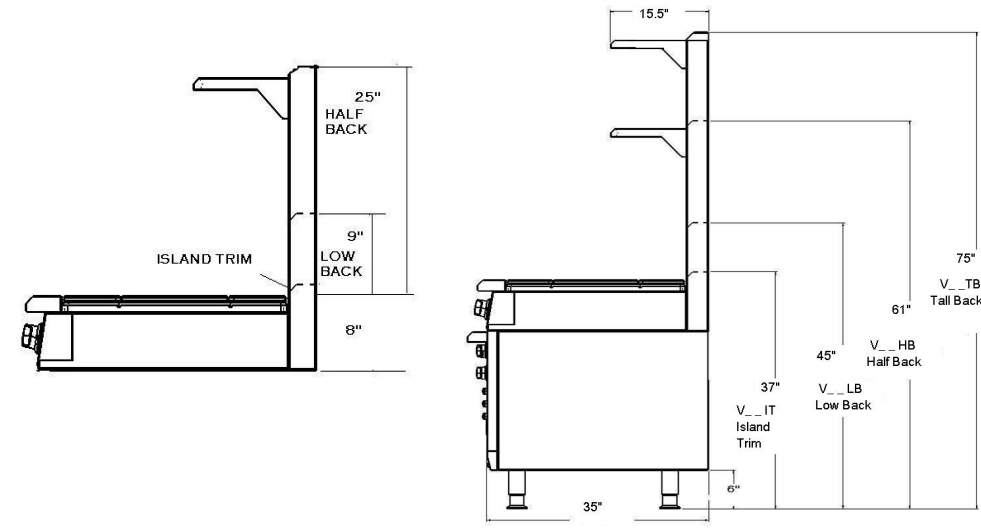
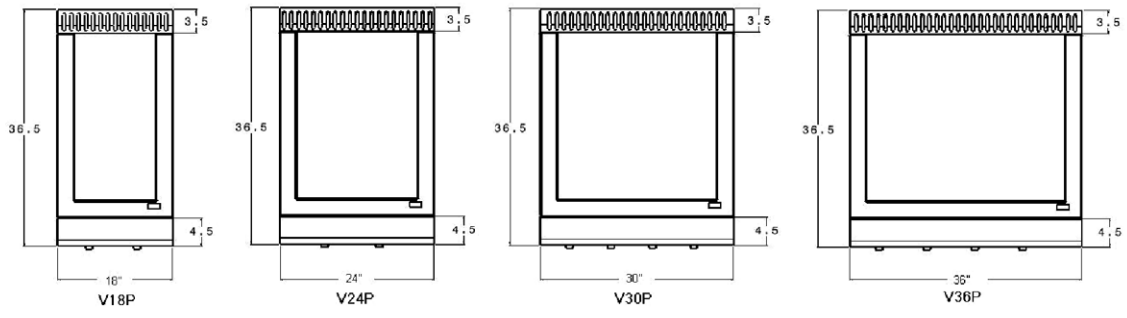

**UTILITY INFORMATION**

Model	Description	Gas [Btu/HR]	Approx SHP WT
V18P	18" wide Plancha	40,000	200 lb
V24P	24" wide Plancha	40,000	260 lb
V30P	30" wide Plancha	80,000	300 lb
V36P	36" wide Plancha	80,000	350 lb

**GAS:** Each unit to have a 1 ¼" front manifold that couples to adjacent equipment or is capped on ends. A 1" male NPT rear gas connection may be used for a gas supply or capped if supply is from adjacent unit(s). Minimum gas supply is 6" W.C. for natural gas and 11" W.C. for propane. Operating Pressure is 5" W.C. for natural gas and 10" for propane at the manifold. All units require a regulated gas supply (pressure regulator must be ordered as an option).

**ELECTRICAL:** No electrical requirements for top modules. Only convection oven base or refrigerated base requires electricity.

**EXHAUST:** Installation under an exhaust hood is required.

Specify type of gas when ordering.  
Specify altitude when above 2000 ft.



**Note:** When used as counter units, the Tall Back risers/shelves are not available. Tall backs are for units with oven, cabinet base or refrigerated base only.

**Note:** In line with company policies, Viking Range Corporation reserves the right to change material and specifications without notice.